

# **Cygnus Hatch Sure**

## **Ultrasonic Hatch Cover / Watertight Door Testing**

# **Operating Manual**



**Doc No. M1-HLD-M-ENG\_Iss14.docx**  
**27-July-2021**  
**(Mk2 Equipment)**

## Contents

<b>1. Introduction.....</b>	<b>5</b>
Cygnus Hatch Sure .....	5
Overview.....	5
Cygnus Instruments.....	6
<b>2. Hatch Sure Kit Contents .....</b>	<b>7</b>
Rechargeable Batteries.....	8
Hatch Sure System Layout.....	8
<b>3. Hatch Sure Transmitter.....</b>	<b>9</b>
Controls .....	10
Audible Tones .....	11
Low Battery Warning.....	11
Remote Control .....	11
Power Requirements .....	12
Batteries .....	12
Battery Precautions.....	12
Changing the Batteries .....	12
Charging the Batteries.....	12
External Power Supply .....	13
<b>4. Hatch Sure Receiver.....</b>	<b>14</b>
Headphone Connection.....	15
Battery .....	15
Battery Precautions.....	16
Changing the Battery.....	16
Charging the Battery .....	16
Receiver Display.....	17
Receiver Keypad Functions.....	18
OH/dB Key.....	18
HOLD/MAX Key.....	19
Power Key .....	19
Backlight Key .....	19
SET OH Key .....	19
Volume Increase/Decrease Keys.....	19
Remote Control Key .....	20
Emitter Test Function .....	20
Setting the Battery Type .....	20
<b>5. Microphone and Telescopic Extension .....</b>	<b>22</b>

Emergency Extension Cable .....	23
Testing Inspection Microphones .....	23
<b>6. Operating .....</b>	<b>24</b>
Open Hatch Values .....	24
Transmitter Power Level .....	24
Setting Open Hatch Value .....	24
Emitter Test Function .....	25
<b>7. Hatch Cover Inspection Guidelines .....</b>	<b>27</b>
Equipment Testing .....	27
Transmitter Positioning .....	27
Tween decks .....	29
Centre Girders .....	30
Long Cargo Holds .....	31
Transmitter Power Level .....	31
How to determine when to reduce the Transmitter power level	31
Setting Open Hatch Values .....	32
Listening for Leaks .....	33
Recording Survey Results .....	35
<b>8. Watertight Door Inspection Guidelines .....</b>	<b>37</b>
General .....	37
Assembly Drawings .....	38
Preparation for Ultrasonic Testing of Doors .....	44
Safety .....	44
Rubber Sealing: Visual Check .....	44
Operation .....	45
Indication .....	45
Other items .....	45
Other possible conflicts .....	45
Test equipment .....	45
Test Setup .....	46
Transmitter Positioning .....	46
Self-Test .....	47
Calibration (Setting 'Open Hatch' Value) .....	47
ULTRASONIC TESTING .....	47
Detection/Tone .....	47
Test result .....	48
Report Sheet for Recording Testing of a Watertight Door .....	49
<b>9. Troubleshooting .....</b>	<b>50</b>
Transmitter Power Seems Low .....	50

Unable to Set an Open Hatch Value ..... 50

Intermittent Receiver Signal Level..... 51

**10. Care, Servicing & Calibration ..... 52**

    Cleaning..... 52

    Batteries ..... 52

    Environmental..... 52

    Repairs ..... 52

    Returning the Equipment for Servicing ..... 53

    Calibration..... 53

**11. Spares and Accessories ..... 54**

**12. Information ..... 55**

    Technical Specifications ..... 55

**13. Recycling and Disposal (EC Countries)..... 58**

**14. Warranty Information..... 59**

# 1. Introduction

## Cygnus Hatch Sure

**Hatch Sure** is a lightweight ultrasonic system for testing the weather tightness of cargo hatch covers or watertight doors. The complete system is contained in a rucksack style carry case for convenient transportation. The complete weight is 3.8 Kg including batteries making it suitable to be carried as hand luggage on aircraft. Hatch Sure is an ABS Type Approved Product.

The transmitter and receiver units are each supplied in a protective case. The receiver case is fitted with neck and waist straps to allow hands free use, ensuring the safety of the surveyor when moving around the vessel. The transmitter case is also fitted with a shoulder strap for convenience and safety.

**Hatch Sure** allows a rapid and thorough test of hatch cover tightness. It may also be used for testing cargo access areas such as bow, side and stern doors or any opening that needs to be sealed.

Unlike hose testing, ultrasonic testing can be conducted in sub-zero weather conditions. Inspections can be carried out with the cargo in place and the testing does not interfere with other crew activities.



This equipment is not intrinsically safe and is not intended for use in hazardous areas.

## Overview

The system consists of a battery powered transmitter containing 19 x 40 KHz ultrasound emitters. The emitters are arranged to produce an omni-directional sound field, uniformly distributed throughout the cargo hold.

The receiver part of the system displays the sound energy level that passes through gaps in the enclosed cargo hold to enable the location of leaks to be quickly and accurately identified.

## Cygnus Instruments

*Cygnus Instruments Limited*, founded in 1983, pioneered the development of the *Digital Ultrasonic Multiple-Echo Technique* used for measurement through coatings. This has long since been the standard required to ensure that accurate measurements are taken without the need to zero the gauge or remove any coatings first.

Our philosophy is to work closely our customers to provide high quality products, engineered to serve heavy industry & harsh environments. Cygnus Ultrasonic thickness gauges are designed to be reliable and simple to use. We have an unrivalled reputation in over 45 countries around the world.



### **CYGNUS Instruments Ltd.**

Cygnus House, 30 Prince of Wales Road,  
Dorchester, Dorset, DT1 1PW England.

Website: [www.cygnus-instruments.com](http://www.cygnus-instruments.com)

Tel: 00 44 (0) 1305 265533

Fax: 00 44 (0) 1305 269960

[sales@cygnus-instruments.com](mailto:sales@cygnus-instruments.com)

### **Cygnus UAE Cygnus Instruments Middle East**

P.O. Box 127267

Jebel Ali Free Zone (JAFZA)

Dubai, UAE

Website: [www.cygnus-instruments.com](http://www.cygnus-instruments.com)

Telephone: +971 50 3459305

E-mail: [sales@cygnus-instruments.com](mailto:sales@cygnus-instruments.com)

### **CYGNUS Instruments Inc.**

Cygnus Instruments, Inc.  
6900 Phillips Hwy, Suite 8  
Jacksonville, FL 32216, USA.

Tel: 00 1 410 267 9771

Fax: 00 1 410 268 2013

[www.cygnusinstruments.com](http://www.cygnusinstruments.com)

[sales@cygnusinstruments.com](mailto:sales@cygnusinstruments.com)

### **CYGNUS Singapore (S) Pty. Ltd.**

63 Jalan Pemimpin  
#04-01 Pemimpin Industrial Building  
Singapore 577219

Tel : (+65) 6252 5909

Fax : (+65) 6251 1318

[www.cygnus-instruments.sg](http://www.cygnus-instruments.sg)

[sales@cygnus-instruments.sg](mailto:sales@cygnus-instruments.sg)

## 2. Hatch Sure Kit Contents

The Hatch Sure kit is supplied in a shower-proof rucksack style soft carry case which can be worn on the back or carried. This allows the user to move about the vessel with both hands free allowing easy climbing or passage through access hatches. The case is sufficiently padded to protect its contents should it be dropped. There is plenty of room for additional items such as chalk, a small torch, a notepad etc.



Fig 2.0 Hatch Sure Kit Contents

The Hatch Sure kit contains the following items

1. Hatch Sure receiver with protective case, neck and waist strap
2. Telescopic extension and cable
3. Two flexible inspection microphones
4. Neck band headphones
5. Hatch Sure transmitter with protective case and carry strap
6. Rechargeable batteries for the transmitter
7. Rechargeable batteries for the receiver
8. Charger for the rechargeable batteries
9. Operation manual
10. External DC power lead for the transmitter (not shown)
11. Emergency microphone cable (not shown)

## Rechargeable Batteries

For safety reasons the Hatch Sure kit is shipped with the rechargeable batteries un-charged. Before using the Hatch Sure equipment charge the batteries fully.

For details on charging transmitter batteries see page 12.

For details on charging receiver battery see page 16.

## Hatch Sure System Layout

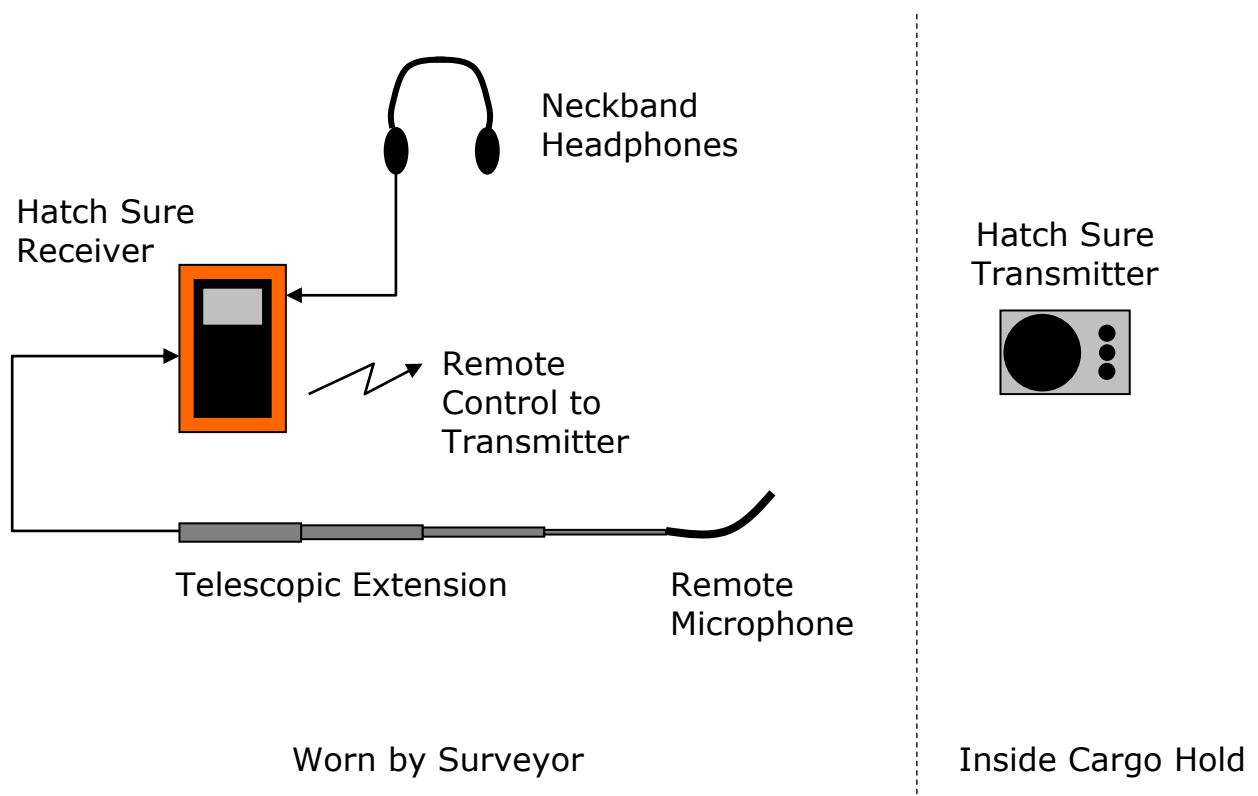



### 3. Hatch Sure Transmitter

The microprocessor-controlled transmitter is supplied in a case for protection during transportation around the vessel. When in use, the lid opens to expose the array of emitters and can be secured open with a Velcro strip.



Fig 3.0 Hatch Sure Transmitter in Protective Case.

The case is fitted with a shoulder strap to enhance safety by leaving the operators hands free when moving around the ship's deck and ladders.

A sling with 4 anchor points is supplied and provides a method of suspending the transmitter unit in the cargo hold if there is no convenient flat surface or if the hold contains a cargo such as grain Fig 3.1.



Fig 3.1 Transmitter Anchor Points & Sling.

The shoulder strap can be used to suspend the transmitter against a flat vertical surface if it is required to test a door or window.

## Controls

There are two rocker switches, a rotary switch and a multi-colour LED on the transmitter top face.



The **On/Off** switch turns the transmitter on and off.

The **Remote** switch when turned on will enable remote control of the transmitter function from the receiver. When turned off the transmitter operates continuously when the power is on.

The **Power Level** control switch has six settings from Min to Max and sets the output power level of the transmitter unit. The Power Level is set to match the size of the area being tested, normally on large bulk-carriers the power level is set to Max, but when testing small cabins or bulkhead doors the power level is reduced accordingly. The actual power level required can be deduced when performing the Open Hatch Value procedure described later on.

The multi-colour **LED** indicates the battery status and flashes when in operation. A flashing green light means the batteries are good. A flashing red light means the battery voltage is insufficient for operation.

**Variable output:** this allows testing of watertight doors and is useful for reducing the dB level or when placing the transmitter on top of cargo close to the hatch cover.

The Receiver will only measure sound levels from 0 to 70 dB, above that the receiver will saturate. To observe the six different sound levels the receiver must be positioned at least 5m away from the transmitter, be aware the sound level measured will be affected by the environment so you may not achieve the exact same dB figures shown. The maximum output is the theoretical sum of all the transmitters if they were all focused on one spot.

## Audible Tones

An audible three-tone signal also alerts the surveyor or anyone in the area the transmitter is working. The audible warning also prevents the unit from being left switched on inadvertently.

## Low Battery Warning

When the batteries in the transmitter are exhausted the LED will flash red and the audible tone changes from the continuous three tones to an intermittent three tone pattern which can also be heard in the surveyors headphones. This helps to ensure there is no possibility of conducting a survey with insufficient power in the transmitter.



Once the transmitter has reached the low battery state the survey should be halted until the transmitter batteries have been replaced.

## Remote Control

The transmitter can be switched on/off by remote control to save battery power by activating the transmitter only when required. This also saves time, as the surveyor does not have to re-enter the hold.

When the transmitter is in Standby mode the green LED will flash every 3 seconds and the transmitter will send a short ultrasound tone every 30 seconds.

## Power Requirements

### Batteries

The transmitter requires 6 x AA batteries, either alkaline or rechargeable can be used. The kit is supplied with 2 sets of 6 'MaxE' 2100mAh rechargeable AA cells and a fast charger.

The 'MaxE' batteries supplied will retain their full charge for up to a year (normally NiMH batteries can lose up to 20% of their charge after a week). This means the user can be sure the batteries are ready for use even if they were charged some time ago.

### Battery Precautions

- ✓ Always remove the batteries from the transmitter when not being used for longer than a few days
- ✓ Always use high quality batteries to avoid leakages
- ✗ Never mix new and used batteries as this can cause the batteries to leak

### Changing the Batteries

To change the batteries un-zip the base to access the battery compartment, there is a removable cover. Make sure the correct polarity is observed when inserting batteries.

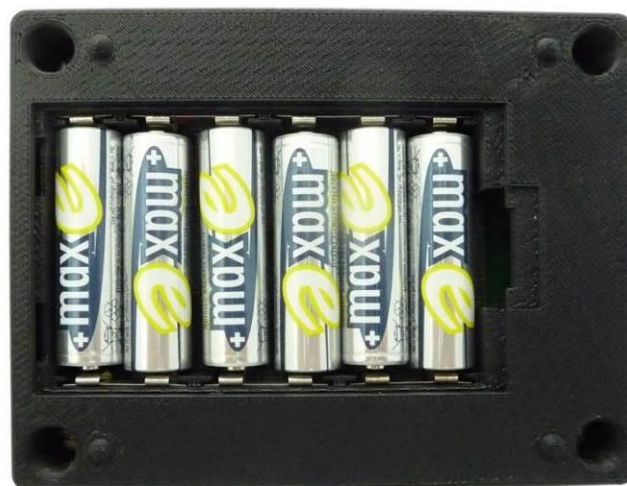

Fig 3.3 Transmitter Battery Compartment.

### Charging the Batteries

A six cell battery charger is supplied that can charge all six AA batteries simultaneously. The maximum charge time is 3 hours.

The charger will operate from 100 to 240 V ac 50-60 Hz supply and is supplied with a European plug and appropriate adapter.



Fig 3.4 Battery Charger.

### External Power Supply

The transmitter will accept an external power supply ranging from 12 to 24 V dc @ 0.5A instead of the internal batteries, allowing the surveyor greater flexibility to carry out a hatch cover inspection without transmitter operational time constraints. The Hatch Sure kit is supplied with a 1.8m power lead terminated in two red and black crocodile clips.

The external power socket is located on the side of the transmitter housing, fig 3.4, and will require removing the transmitter from its pouch to access it.

The external power socket accepts a 2.5mm type power plug with the centre pin being positive. There is reverse polarity protection on this input.



Fig 3.4 External 12-24 V dc Power Input

## 4. Hatch Sure Receiver

The receiver is supplied in a weatherproof case fitted with neck and waist straps for convenient and safe hands free operation.



Fig 4.0 Hatch Sure Receiver

The receiver can be easily removed from the case by opening the zip fastener to gain access to the battery compartment. The receiver is further protected by an outer orange rubber cover which can also be removed.

The BNC connector for the inspection microphone is located at the rear of the receiver case, see Fig 4.1.



Fig 4.1 BNC Connection for Microphone

The receiver unit has a built in loudspeaker giving the operator an indication of the sound level, without having to plug in the headphones.

## Headphone Connection

The headphone socket will accept any type of headphones with a 3.5 mm jack plug. It will work with stereo, mono headsets or single earpieces. The headphone socket is located on the right hand side of the receiver through a hole in the orange protective cover, see Fig 4.2.



Fig 4.2 Headphone Socket

This has been designed to allow the surveyor the choice of any headset they prefer or have available.

The kit is supplied with neckband style headphones which can be worn under a protective safety hat.

## Battery

The receiver requires a single 9 V PP3 alkaline or rechargeable battery. The kit is supplied with two MaxE rechargeable 9 V batteries.

The 'MaxE' batteries supplied will retain their full charge for up to a year (normally NiMH batteries can lose up to 20% of their charge

after a week). This means the user can be sure the batteries are ready for use even if they were charged some time ago.

### Battery Precautions

- ✓ Always remove the batteries from the transmitter when not being used for longer than a few days
- ✓ Always use high quality batteries to avoid leakages
- ✗ Never mix new and used batteries as this can cause the batteries to leak

### Changing the Battery

The battery is located behind a removable cover on the rear of the receiver enclosure. Remove the receiver from its orange protective case to access this cover, see Fig 4.3.



Fig 4.3 Receiver Battery Location

### Charging the Battery

A battery charger is supplied that can charge both 9 V PP3 batteries simultaneously. The maximum charge time is 5 hours. The charger will operate from 100 to 240 V ac 50-60 Hz supply and is supplied with a European plug and appropriate adapter.



## Receiver Display

The receiver has a large clear LCD display that can be illuminated for use in dark conditions. The display shows the received ultrasound signal level in either dB or Open Hatch units along with a bargraph.

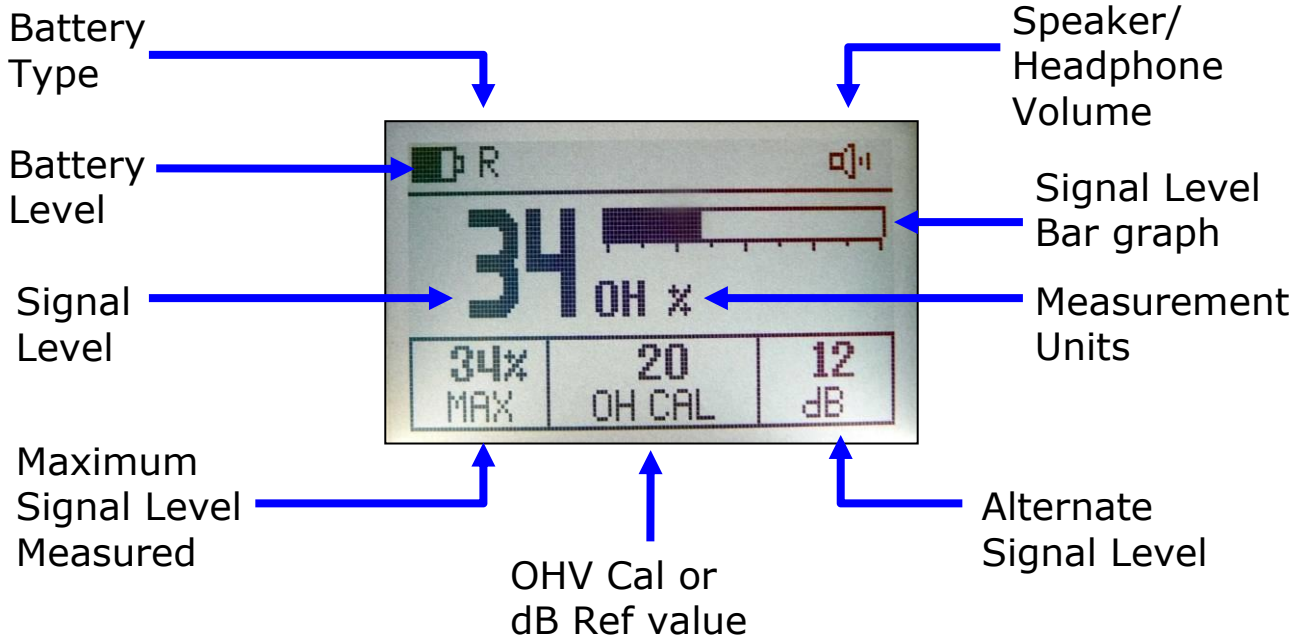

<b>1.</b>	Battery Level	This shows the battery charge level. A solid black icon means a full charge, as the battery runs down the amount of solid black will reduce to the left  A low battery warning message is flashed at the top of the screen when the battery is almost flat
<b>2.</b>	Battery Type	The R or D denotes what type of batteries have been selected, either Rechargeable or Disposable.
<b>3.</b>	Signal Level	This large number shows the received ultrasonic signal level in real time
<b>4.</b>	Maximum Signal Level Measured	The receiver will keep track of the maximum signal level and display it here. This is useful when scanning an area looking for a maximum leak point

<b>5.</b>	OH Cal or dB Ref value	This value shows the calibration factor or reference value used to set the 100% Open Hatch Value.
<b>6.</b>	Alternate Signal Level	This shows the signal level in the other measurement unit, i.e. if dB is selected as the main units then this value will show OH units
<b>7.</b>	Measurement Units	This indicates the main measurement units, either dB or OH (Open Hatch)
<b>8.</b>	Signal Level Bar graph	This displays the signal level as a horizontal bar graph. This is useful when scanning for leaks as you can look for increases in the bar graph as you locate leaks
<b>9.</b>	Speaker/ Headphone Volume	This shows the current volume level, more vertical lines means louder volume

### Receiver Keypad Functions



OH dB	HOLD MAX	Power
Backlight	SET OH	Volume increase
Remote		Volume decrease

Fig 4.5 Hatch Sure Receiver Keys

#### OH/dB Key

Press to change the main display units between Open Hatch (OH) and decibel (dB) scale.

## HOLD/MAX Key

Press to freeze the display so it holds the current reading. Press again to release the display from hold. When held the message HOLD is displayed at the top of the screen.

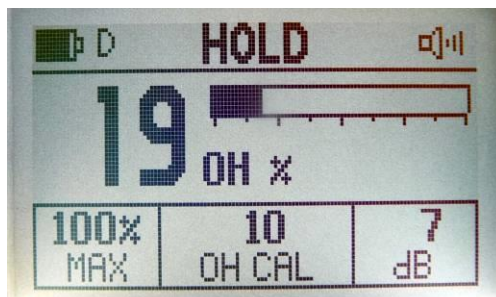

HOLD Mode

Press and hold for 3 seconds to Reset the MAX signal level value. A RESET MAX message will briefly be displayed.



Reset MAX

## Power Key

Press to power up the instrument. Press and hold to turn off the power.

## Backlight Key

Press to toggle the display backlight on and off.

## SET OH Key

Press and hold causes the receiver to start setting the 100% open hatch level.

## Volume Increase/Decrease Keys

Press to adjust the headphone/speaker volume in 2dB steps. Press and Hold to adjust the volume continuously.

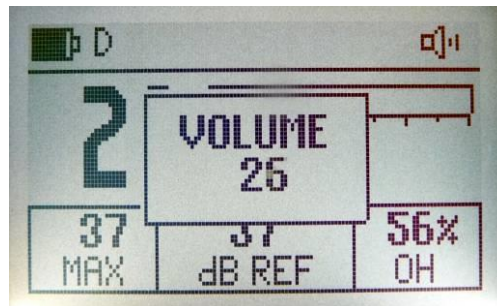

Volume Adjust Message

### Remote Control Key

Press to change the transmitter from Standby to Operating using the remote control link. Note, the transmitter Remote switch must be in the ON position (I).

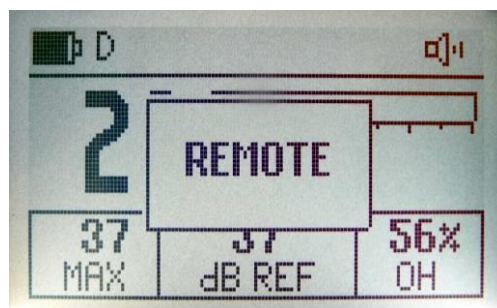

Remote Active Message

### Emitter Test Function

Press and hold both the Volume keys together to start the Emitter Test function.

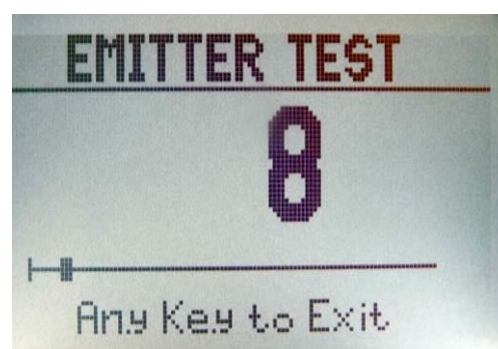

Emitter Test Screen

### Setting the Battery Type

The receiver will operate from either disposable or rechargeable batteries, but to allow the receiver to correctly display the battery

level and warn when the battery is getting low the receiver can be set for the type of 9 V battery in use. At the top of the receivers screen either a **R** or **D** is shown for rechargeable or disposable respectively. To switch between the two types simply press and hold the **OH/dB** and **HOLD/MAX** buttons together until the letter changes.



*Note. An incorrect battery type setting will not affect the operation or performance of the receiver.*

## 5. Microphone and Telescopic Extension

The inspection microphone is used to search for leaks around the cargo hatch seals. It consists of an ultrasonic receiver mounted on a 200 mm stainless-steel flexible gooseneck. A rubber end sleeve is fitted to eliminate contact noise while surveying, see Fig 5.0.



Fig 5.0 Inspection Microphone

**!** Ensure the receiver end of the microphone does not get immersed into liquids as this will prevent detection of ultrasound.

To allow the surveyor to reach all areas of the hatch seal a telescopic extension is supplied, Fig 5.1. This extension piece can extend up to 1.2 m (4 feet) in length. The inspection microphone is connected on the end of the extension with a BNC connector, see Fig 5.2.



Fig 5.1 Telescopic Extension with Wrist Strap



Fig 5.2 Inspection Microphone Connected to the Telescopic Extension

## Emergency Extension Cable

A 2 metre (6 ft.) emergency extension cable is supplied with the kit should a problem arise with the telescopic extension. This can allow a survey to be carried out while a replacement or repair is sourced.

## Testing Inspection Microphones

The inspection microphone can be tested by performing an Emitter Test (page 25). If the microphone is faulty or has internal fluid damage then none of the emitters will appear to pass the Emitter Test. You can then perform a comparative test with the other inspection microphone that will identify which microphone is faulty.

## 6. Operating

### Open Hatch Values

The Open Hatch Value is the ultrasound signal level measured by the receiver when the hatch cover is fully or partially open or through an access hatch. This signal level is then set to indicate 100%. When looking for leaks the percentage scale is simple to understand. See page 32 for more information on Open Hatch values.



### Transmitter Power Level

When setting the Open Hatch always start with the transmitted power level set at Max. If you are testing a small cabin on the deck area then you will probably need to reduce the power level to suit – in practice you should only reduce the power level if you find ultrasound is penetrating through the steel and you can't get a 0% reading anywhere.

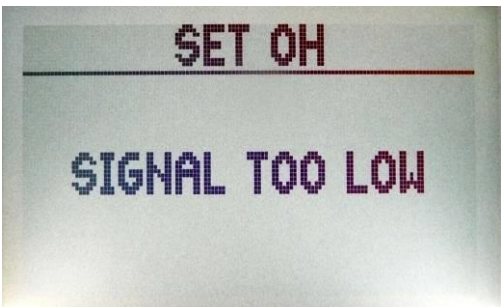
### Setting Open Hatch Value

<b>1.</b>	Assuming the microphone is in position and the transmitter is operating normally	
<b>2.</b>	Press and hold the SET OH key	<b>SET OH</b>
<b>3a</b>	<p>If the signal is too weak this message is shown</p> <p>Is the transmitter turned on? Is the microphone connected? Has the transmitter moved?</p>	

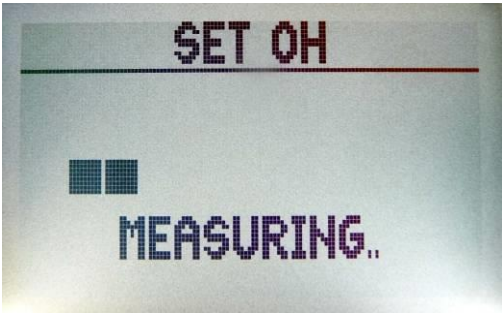



<p><b>3b</b></p>	<p>If the received signal is within the correct range this message is shown while the signal level is evaluated. The progress bar will fill to the right while the receiver is measuring</p>	
<p><b>4.</b></p>	<p>When the signal level has been measured the screen displays the OH signal level set at 100% and the OH CAL value</p>	
<p><b>5.</b></p>	<p>You can now use the Volume UP and DOWN arrow keys to adjust the calibration value if required.</p> <p>Each key press changes the OH CAL value by 1</p>	
<p><b>6.</b></p>	<p>After 2 seconds of no key presses the screen changes back to the normal measuring screen and the new OH calibration is applied and saved.</p> <p>This new open hatch calibration value will be saved into memory and retained even while the receiver is turned off or the batteries are removed.</p>	

### Emitter Test Function

The receiver may be used to quickly test each emitter is producing sufficient ultrasound energy. This would typically be carried out at the start of each survey. This test should be carried out with the foam mic cover removed.

<p><b>1.</b></p>	<p>Turn on the transmitter. Make sure the Remote switch is in the Off (0) position and the Power level is set to MAX.</p>
------------------	---

<p><b>2.</b></p>	<p>Connect the microphone to the receiver either directly or using the telescopic extension. Remove the foam mic cover.</p>	
<p><b>3.</b></p>	<p>On the receiver press and hold both the Volume UP and DOWN keys until the Emitter Test screen is displayed</p>	
<p><b>4.</b></p>	<p>Place the inspection microphone over each emitter and observe the value on the receiver screen</p>	
<p><b>5.</b></p>	<p>A reading above 50% for a good emitter and the words "OK" will be displayed on the right.  Anything less indicates a potentially faulty emitter</p>	
<p><b>6.</b></p>	<p>There will be a small fluctuation in the readings – this is normal  Also each emitter will generate slightly different levels of ultrasound – this is normal</p>	
<p><b>7.</b></p>	<p>If it's found 1 or 2 emitters are not working then the hatch cover inspection could still be carried out. You will then need to return the transmitter for repair as soon as possible</p>	
<p><b>8.</b></p>	<p>When you have completed the test press any key to exit the Emitter Test screen</p>	

## **7. Hatch Cover Inspection Guidelines**

The process of carrying out a hatch cover inspection requires training and experience so the surveyor can evaluate the many different situations and types of vessels that will be encountered. It is therefore beyond the scope of this manual to produce a detailed guide to the whole subject of hatch cover testing.

### **Equipment Testing**

It is advised that you perform an Emitter Test (page 25) before and after carrying out any survey to establish the equipment is and has been functioning correctly throughout the survey.

### **Transmitter Positioning**

Cargo holds come in a variety of sizes and shapes, some have internal obstructions such as centre girders or tween decks and some can be long and narrow so choosing the right place to position the transmitter is vital when planning a successful survey.

The ultrasound energy will travel in a straight line from the 19 emitters, forming a cone shaped beam as it moves away from the transmitter. As the 19 emitters are equally positioned in a radial pattern the sound field will cover a wide area as shown in Fig 7.0

However tests have also shown that in an enclosed space such as a cargo hold the signal level is less attenuated and more evenly distributed. For an area of 15m x 25m x 6m (LxWxH) with the transmitter placed in the centre of the floor the lowest signal level measured, i.e. the furthest corner away, was -20dB down from the reference level (20dB = 10 times less).



Fig 7.0a Transmitter Beam Spread Pattern (side view)

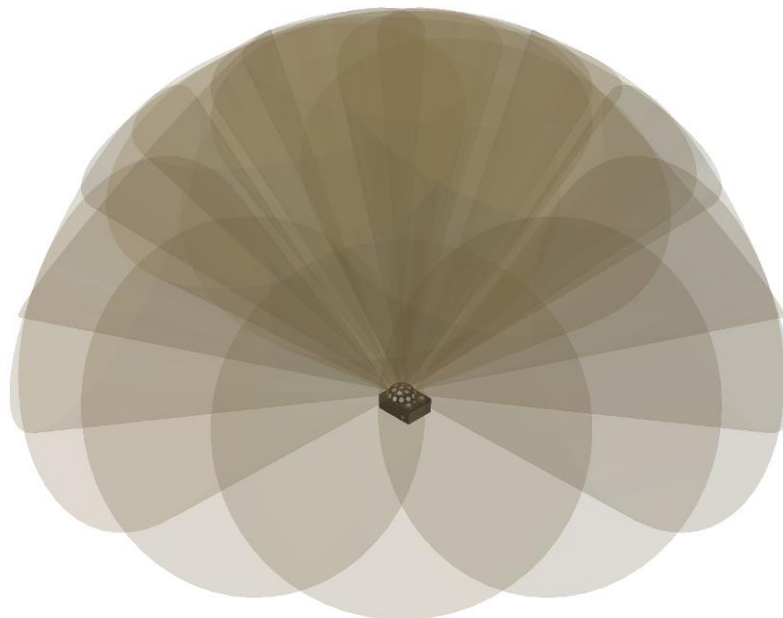

Fig 7.0b Transmitter Beam Spread Pattern (oblique view)

When choosing a transmitter position, try to produce a uniform sound field that will arrive at the rear of the whole hatch sealing area. If there are internal obstructions that may cause ultrasound shadows or quiet areas consider moving the transmitter and carrying out the survey in two stages.

Ultrasound will however bounce off flat steel surfaces and get into most areas but it can also be absorbed by softer materials such as the cargo itself.

The simplest situation is an almost square cargo hold without any internal obstructions, here the transmitter is placed in the centre of the hold and the survey can be carried out without having to move the transmitter, see Fig 7.1 which shows a section through a bulk carrier.

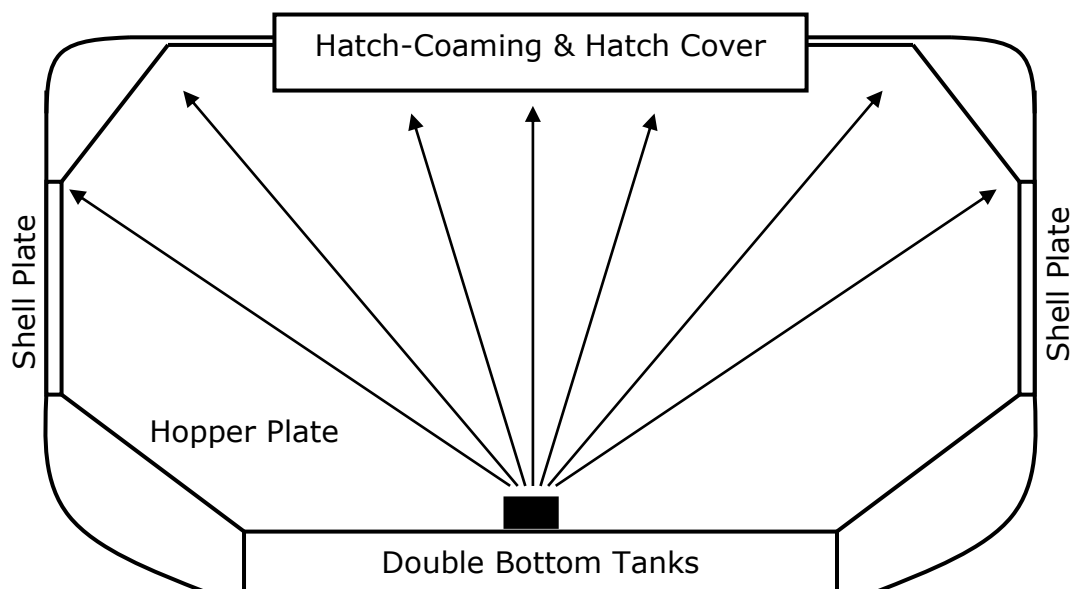

Fig 7.1 Transmitter Centrally Positioned.

### Tween decks

If the cargo hold has a tween deck then the ultrasound level above these areas will be reduced due to the indirect path travelled by the ultrasound as it bounces off the internal surfaces as shown in Fig 7.2. If possible position the transmitter in the tween deck hatch area.

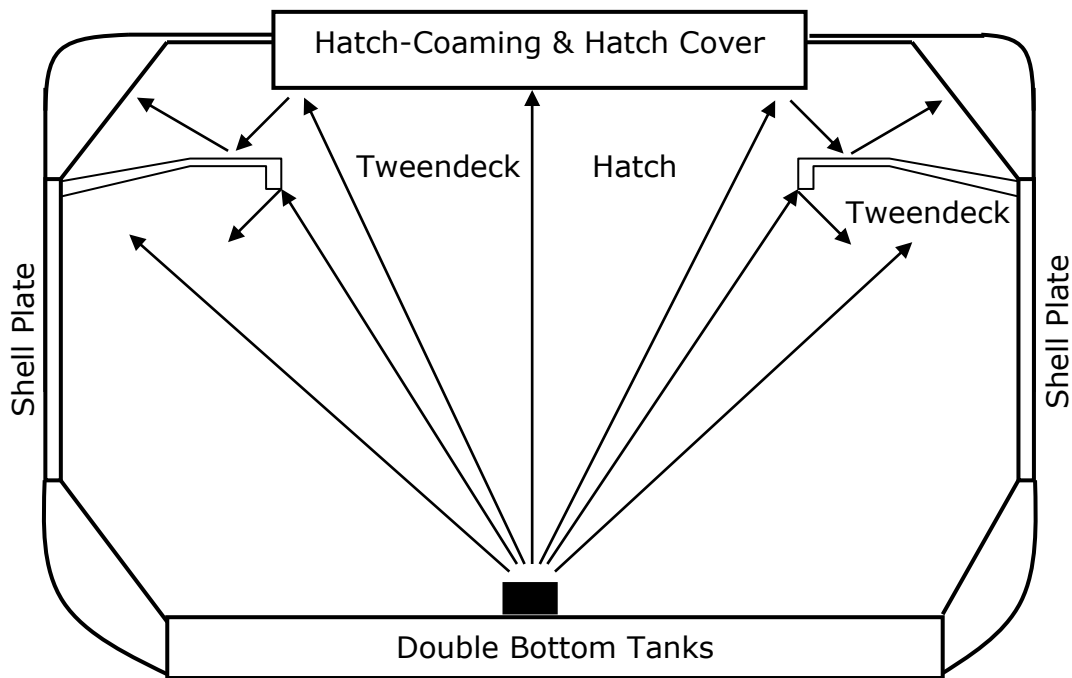

Fig 7.2 Cargo Hold with Tweendeck

### Centre Girders

If the cargo hold has a centre girder and two hatch covers they must be tested separately with the transmitter placed beneath each hatch cover, as shown in Fig 7.3.

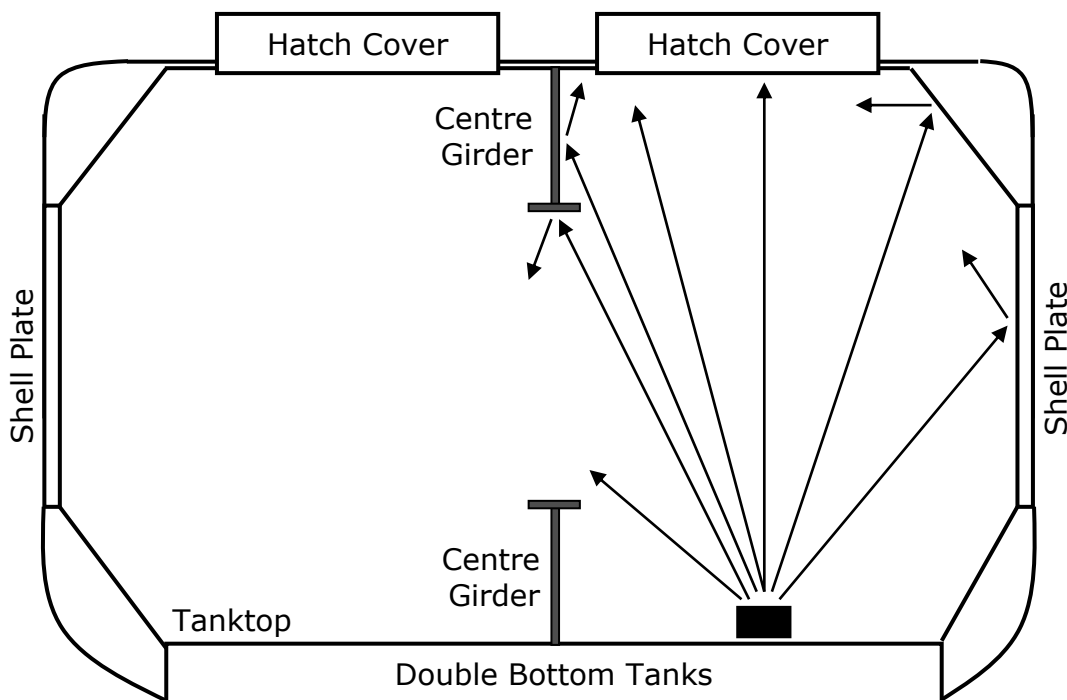

Fig 7.3 Cargo Hold with Centre Girder

## Long Cargo Holds

Some vessels have long narrow cargo holds (i.e. 11m wide 55m long). To carry out an ultrasonic survey the hold area must be tested in separate sections, where each section is close to square, shown in Fig 7.4. The transmitter is positioned in the centre of first section, the leak survey performed as normal started by taking an Open Hatch value, then the transmitter is moved to the centre of the next section and the survey repeated.

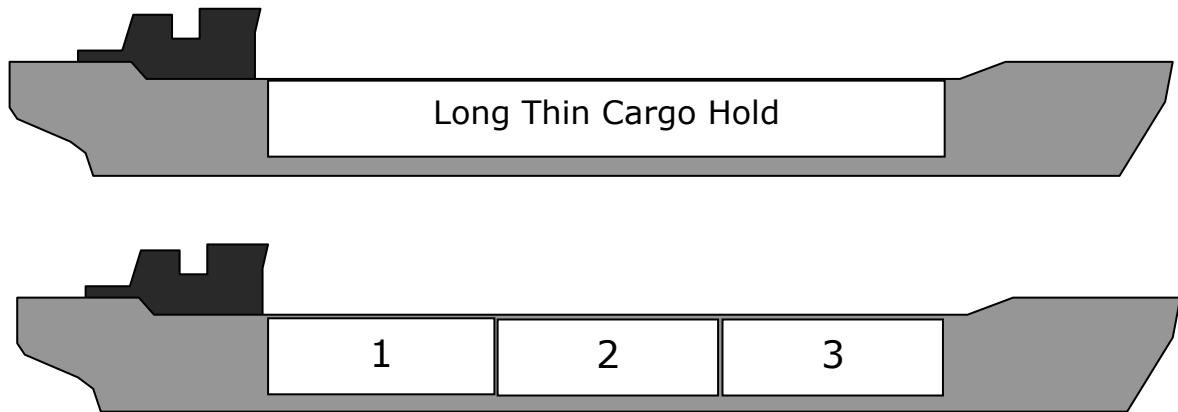

Fig 7.4 Dividing Long Cargo Holds into Separate Sections for the Purpose of Testing.

## Transmitter Power Level

The Transmitter is equipped with 6 positions of Power level from Min to Max. For hatch cover testing on large vessels the Max power level should be used. However when testing small vessels, deck cabins or bulkhead door seals the power may need to be reduced accordingly.

### How to determine when to reduce the Transmitter power level

Before testing is carried out a check should be done to confirm that the transmitter power level has not been set too high. The following is a guide to aid diagnosing this situation.

1. You are testing a small enclosed space, bulkhead or water tight door and ultrasound is passing through the steel door.
2. All the opening and doors are closed to seal the space. The inspection microphone is held near the surface of the steel

door, away from the all the seals and ultrasound is detected passing through the middle of the door.

3. If 1 or 2 is true then the power level on the transmitter should be reduced by one level and another check should be carried out before testing.

## Setting Open Hatch Values

The purpose of the Open Hatch Value (OHV) is to set a 100% reference using the current ultrasound signal level. This provides a percentage scale that can easily assess the severity of any leak that is detected, for example any leak over 10% OH would be considered not weather-tight.

To set the Open Hatch Value one hatch cover is partially opened so the inspection microphone can be inserted into the gap directly above the transmitter as shown in Fig 7.4.

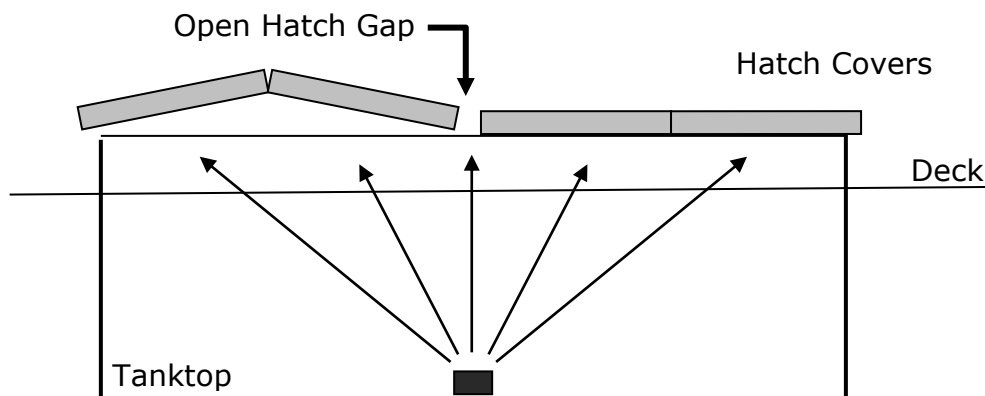

Fig 7.4 Open Hatch "Gap"

It has also been demonstrated that using a cargo hold access hatch can achieve similar results as long as the sound path to the transmitter is unobstructed i.e. opens directly into the hold (Fig 7.5).





Fig 7.5 Setting an Open Hatch Value using an Access Hatch

When attempting to set the Open Hatch Value there are two extremes to be aware of;

1. Too much ultrasound signal – Too close to the transmitter (or the cargo area is very small) the ultrasound energy may saturate the receivers input or the ultrasound energy may penetrate through the steel and you cannot get a 0% reading anywhere. The receiver will report that it is unable to set an Open Hatch value due to a high signal level. In this case try reducing the power level of the transmitter unit with the power control.
2. Too little ultrasound signal – If the cargo area is very large (long) and the receiver is simply too far away from the transmitter the ultrasound energy may be below the minimum required to set an Open Hatch Value. In this case consider splitting the area into smaller sections. Also perform an Emitter Test to verify the transmitter is performing correctly (see page 25). Also confirm that the transmitter unit is set to MAX power.

## Listening for Leaks

Once the Open Hatch Value has been set and the hatch covers and access hatches have been closed you are ready to start looking for leaks. Unless the hatch covers are perfectly sealed you may hear

small amounts of ultrasound leaking around hinged joints or corners of the hatch covers. Sometimes cargo hold vent covers are un-cleated and ultrasound will leak from there too. If you are not hearing any ultrasound leaks be suspicious/careful - is the transmitter turned on?

When looking for leaks, using the headphones is the quickest method of scanning along a joint as the ultrasound will be heard before it registers on the receivers display. Once the ultrasound has been heard the surveyor can stop, focus on the area and pinpoint the leaky section then chalk mark it clearly.



Fig 7.6. Scanning a Hatch Cover Joint.



Fig 7.7. Pinpointing a Leaky Seal.



Fig 7.8. Scanning a Deep Hinged Joint.

## Recording Survey Results

When conducting a hatch cover survey the methods for marking and recording areas where leaks have been identified will vary for the party requiring the survey so recommendations for formats are beyond the scope of this manual, however a typical format is shown in Fig 7.9. In addition to this information the surveyor

should always record the OH CAL value and Reference dB value obtained after setting the Open Hatch value.

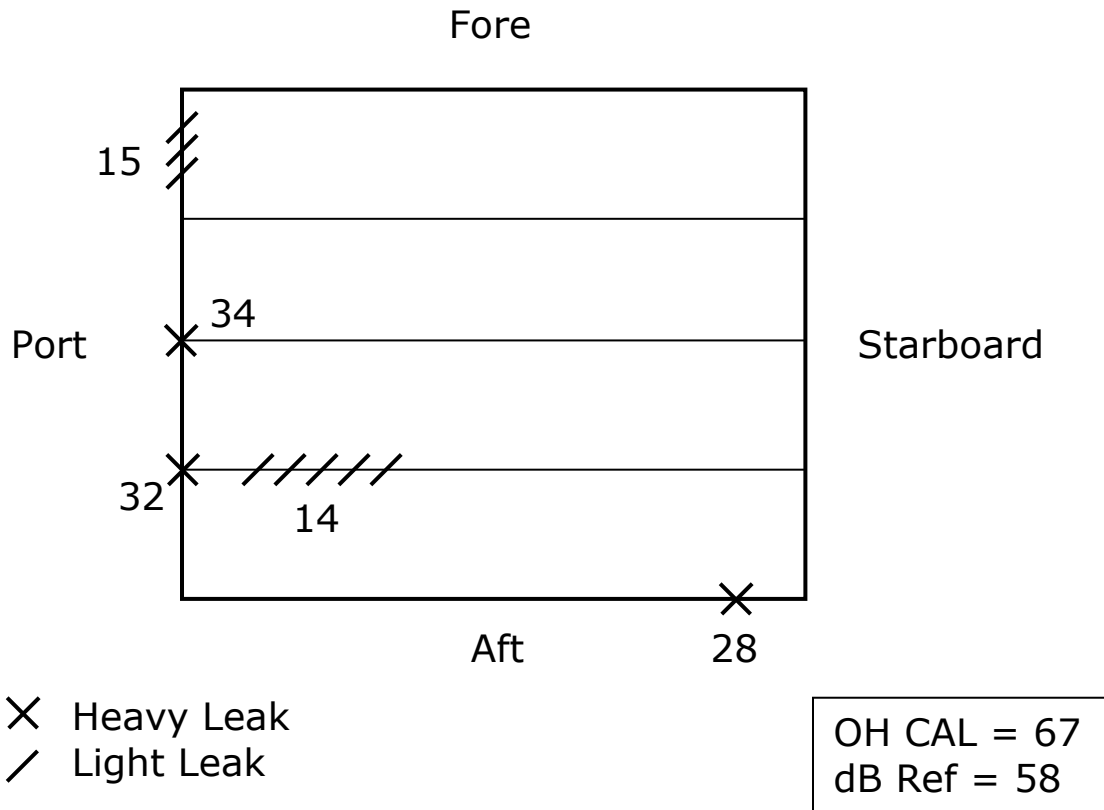

Fig 7.9 Typical Hatch Cover Survey Results

## 8. Watertight Door Inspection Guidelines

### General

The use of ultrasonic testing is not only a sure way of detecting any damage to the doors seal; it can also identify the loss of any watertight integrity that may have occurred during the installation phase of the watertight door. This can include deformation to the frame or other misalignments.

The ultrasonic test of the door sealing and the door system is to be made in accordance to eventual flag authority and classification society rules.

Test frequency: Upon request or replacement of rubber sealing on the watertight doors.

The frequency of testing shall be in accordance with any relevant regulations from SOLAS, the particular authority and classification society. Where such demands are not present or applicable, the following frequency is proposes:

- During commissioning
- After replacement of rubber sealing
- On request from customers or class society.

## Assembly Drawings

The location for each item listed below is shown on page 39.

<b>Position Number</b>	<b>Item</b>
1.	Warning bell
2.	Bottom rail
3.	Cover plate
4.	-
5.	-
6.	Door blade
7.	Door frame
8.	Handle for cover plate
9.	Handle for operation
10.	Handle for generator
11.	-
12.	Generator bracket
13.	Rubber sealing
14.	Terminal box
15.	Top rail
16.	Top rail bracket
17.	Wheel, top
18.	Wheel, bottom front
19.	Wheel, bottom rear
20.	Signs hand-generator
21.	Signs instruction
22.	Signs open/close

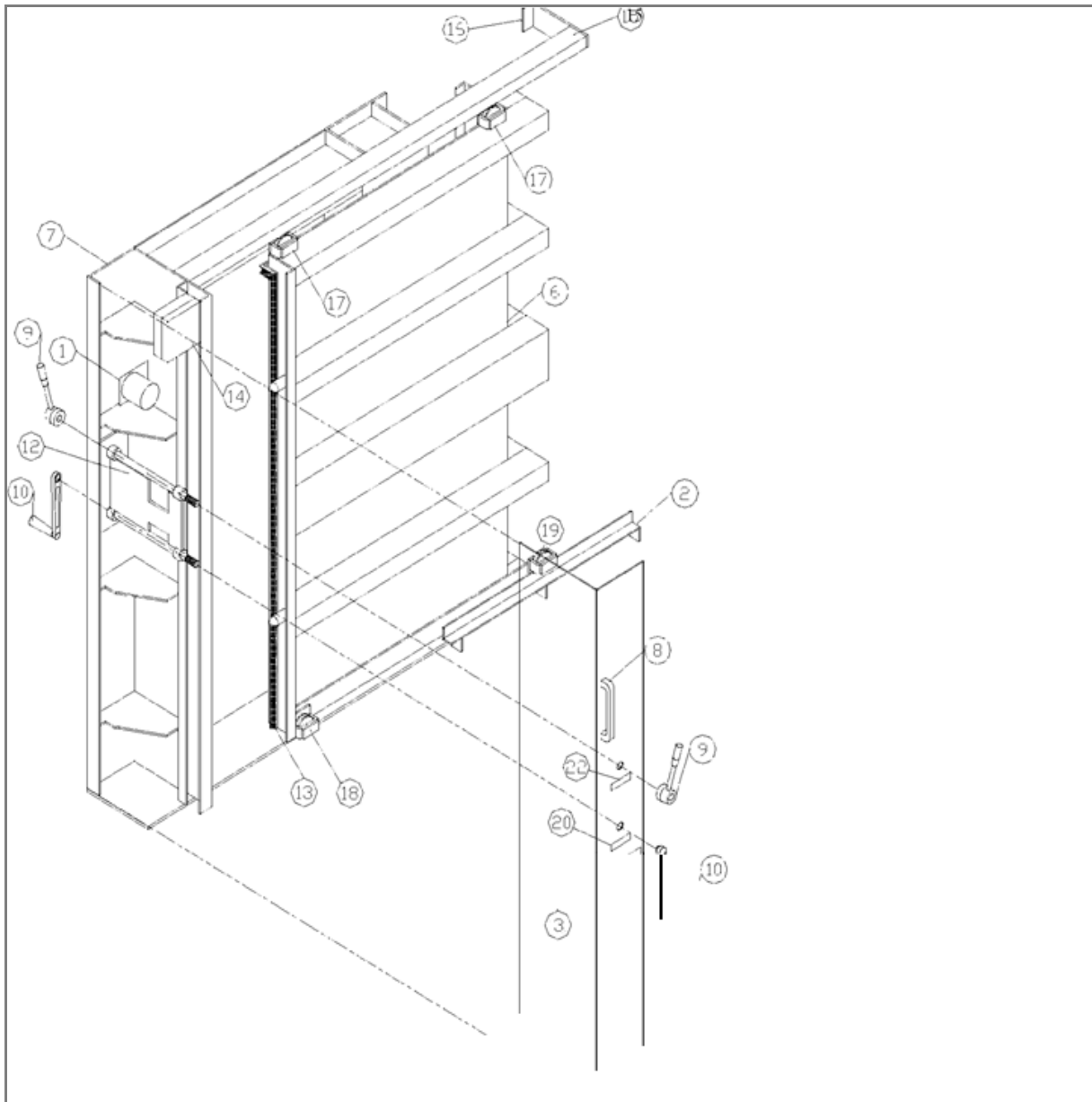

Figure 8.1 Assembly drawings for Electrical door

The location for each item listed below is shown on page 41.

<b>Position Number</b>	<b>Item</b>
1.	Accumulator (main)
2.	Accumulator (additional)
3.	Bell
4.	Bottom rail
5.	Connection block
6.	Cover plate
7.	Cylinder
8.	Cylinder bracket
9.	Door blade
10.	Door frame
11.	Handle for cover plate
12.	Handle for operation valve
13.	Handle for pump
14.	Inductive switch
15.	Motor electric
16.	Motor starter coil
17.	Power pack
18.	Pump bracket
19.	Rubber gasket
20.	Signs hand-pump
21.	Signs instruction
22.	Signs open/close
23.	Steering block
24.	Terminal box
25.	Top rail
26.	Top rail bracket
27.	Wheel, top
28.	Wheel, bottom front
29.	Wheel, bottom rear



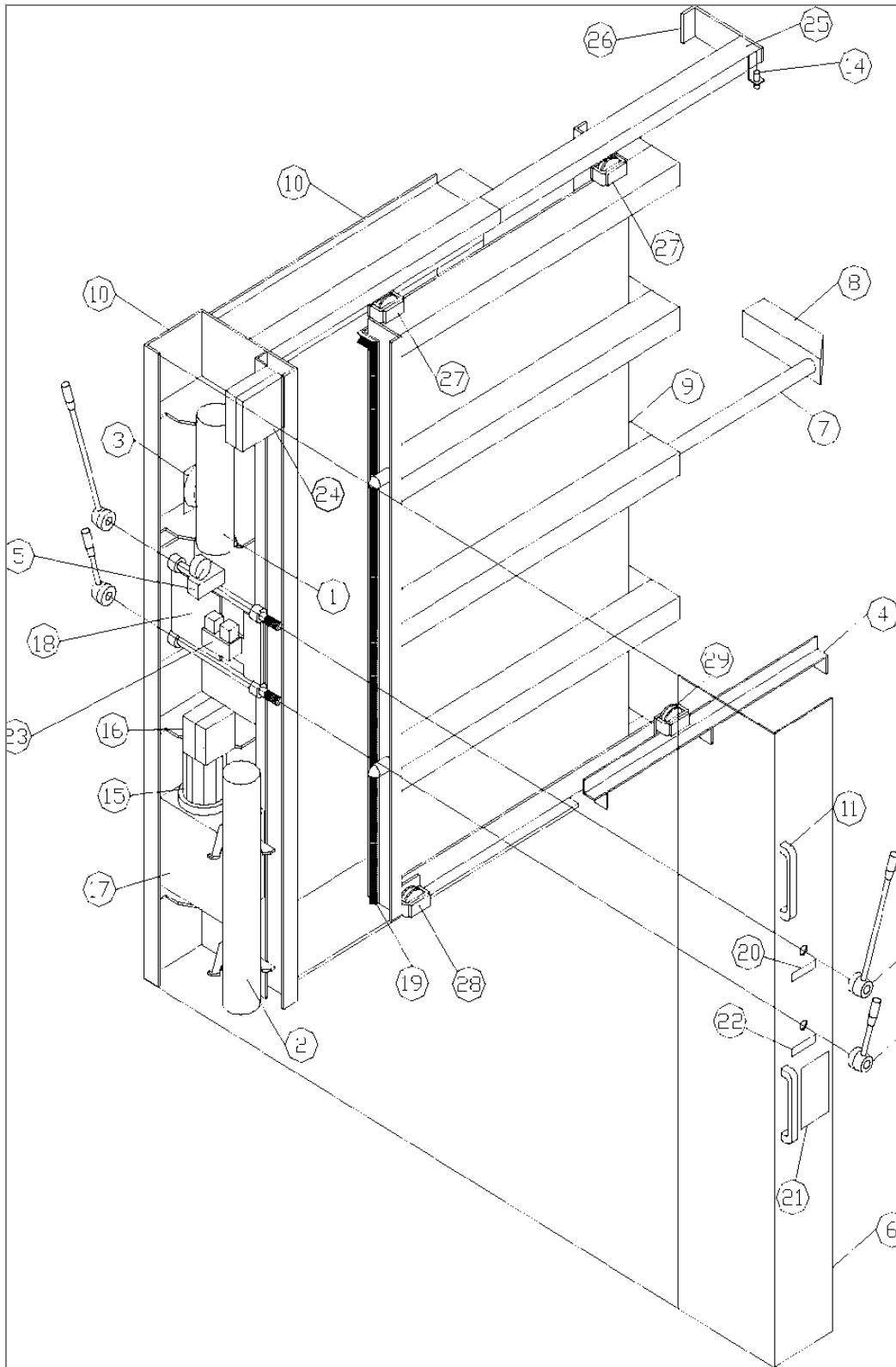

Figure 8.2 Assembly drawings for F-12, MR, AH

The location for each item listed below is shown on 43.

<b>Position Number</b>	<b>Item</b>
1.	Accumulator (additional)
2.	Accumulator (main)
3.	Bell
4.	Bottom rail
5.	Bottom rail bracket
6.	Connection block
7.	Cover plate
8.	Cylinder
9.	Door blade
10.	Door frame
11.	Handle for cover plate
12.	Handle for operation valve
13.	Handle for pump
14.	Inductive switch
15.	Motor electric
16.	Motor starter coil
17.	Power pack
18.	Pump bracket
19.	Rubber gasket
20.	Signs hand-pump
21.	Signs instruction
22.	Signs open/close
23.	Steering block
24.	Terminal box
25.	Top rail
26.	Top rail bracket
27.	Wheel

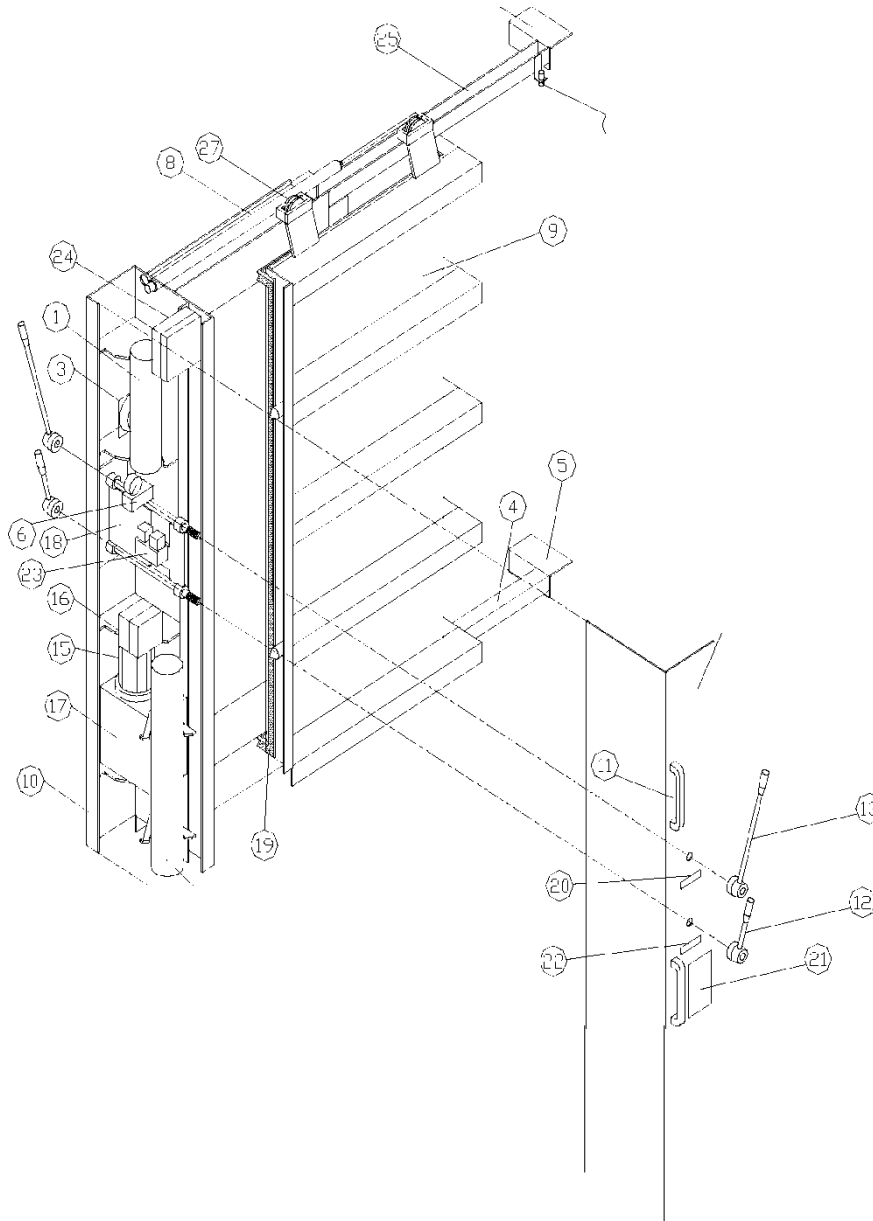

Figure 8.3 Assembly drawing for N200 / N280

## Preparation for Ultrasonic Testing of Doors

Before testing ensure that all watertight sliding doors are in “Local Control” mode at the control station (bridge). Ensure that there are no foreign objects behind the door blade that can damage the rubber sealing.

### Safety

<b>1.</b>	Caution shall be exercised at all times while Ultrasonic testing is ongoing
<b>2.</b>	Where the Ultrasonic test is to be carried out, the complete area shall be cordoned off
<b>3.</b>	Warning signs “Ultrasonic test in progress” (in English and local languages) shall be prominently displayed at strategic locations and remain in place until testing is completed
<b>4.</b>	Only authorized personnel who have been signed off as a part of the inspection/commissioning team shall be allowed in the area at the time of testing
<b>5.</b>	Personnel engaged in the testing shall be kept to a minimum
<b>6.</b>	Testing of the watertight doors must comply with any local Permit to Work (PTW) procedures
<b>7.</b>	Before testing shall begin, the captain and the officer of the watch shall be informed and a warning sign shall be placed at the Master Closing Switch, as unauthorized closing can be dangerous

### Rubber Sealing: Visual Check

The door must be closed during this check. Check behind door blade for any foreign objects before closing.

<b>1.</b>	Door side of bulkhead: Use a flashlight and check that the rubber seal rests on the steelworks (no gaps). It is possible to see the rubber seal all the way around
-----------	--

- 2.** Bulkhead side of door: See (check with your fingers) that the rubber seal rest on the steelworks (no gap). If you can't feel the rubber seal all the way around (Difficult access behind the HUP integrated doorframe), use an inspection mirror

**Operation**

Close the door and check that the mechanical lock falls down completely.

**Indication**

Check for door closed indication, green light at the control station (bridge).

**Other items**

Check that all bulkhead penetrations in the immediate area to the door are closed/sealed. Failure to do so can result in an unsuccessful test.

**Other possible conflicts**

Work in close proximity to the watertight door involving electrical tools or machinery that can emit high frequency sounds, for example angle grinders, should be stopped during ultrasonic testing. Failure to do so can result in an unsuccessful test.

**Test equipment**



Transmitter



Microphone

Receiver



*The Ultrasonic Door Leak Detector equipment has been approved:*



## Test Setup

### Transmitter Positioning

Position the transmitter at a distance not less than the maximum dimension of the door, e.g., if the door is 2000mm x 1100mm, the distance X should not be less than 2000mm (See Figure 8.4)

*Note: Some doors have a greater width (W) than height (H) so W becomes X in Figure 8.4.*

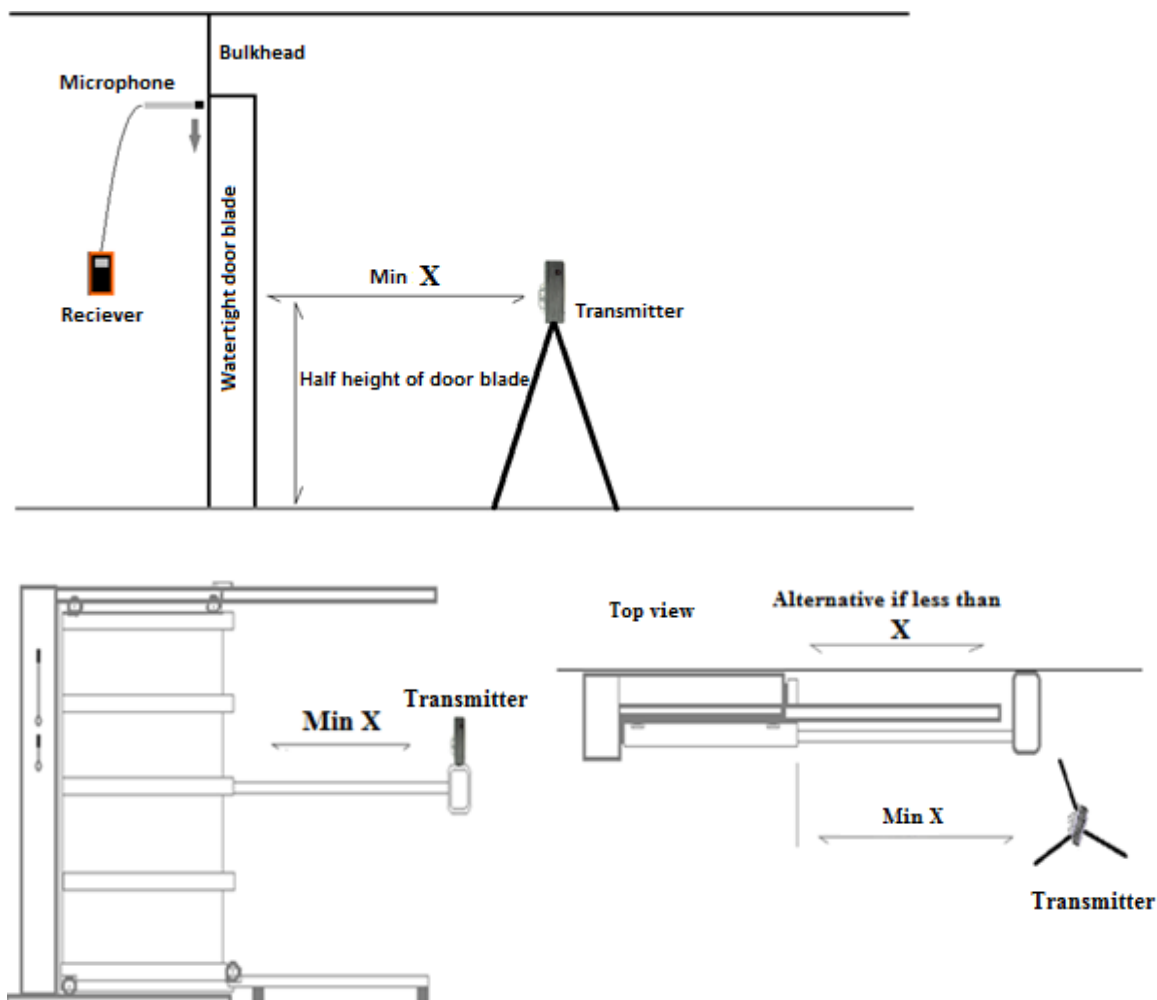

Figure 8.4 Minimum distance from door under test

## Self-Test

After powering up the equipment a function test of the transmitters' emitters shall be carried out (see page 25). A reading of over 40% in the receivers LED display along with an "OK" shows that the equipment is working correctly.

## Calibration (Setting 'Open Hatch' Value)

With the door in an open position the receiver shall be calibrated to indicate an open hatch value of 100% (see page Setting Open Hatch Value On page 24)

*The purpose of an Open Hatch Value (OHV) is to set a 100% reference using the current ultrasound signal level. This provides a percentage scale that can easily assess the severity of any leaks that are detected, for example a leak over 10% OH would be considered not weather tight.*

## ULTRASONIC TESTING

When the door has been fully closed, with the transmitter set to position 2; and standing on the opposite side of the bulkhead to the transmitter, the microphone shall be slowly passed close to the seal around all four sides of the door blade. A reading of 0% is to be considered that a high level of watertight integrity has been achieved.

### Detection/Tone

Notice has to be taken that the unique tone emitted by the transmitter is to be used as a guide to locate a potential leak. The detection of the tone using the earphones does not determine an actual leak; it is only to show a specific point that should be further investigated.

Criteria for judgment with detection of ultrasonic tone leak:

<b>A</b>	With low contact force between gasket and frame due to frame distortion, incorrect cleating etc.: Needs extra investigation and corrections
<b>B</b>	With damage or wear of the rubber gasket: The rubber gasket should be replaced by a trained service technician.

**C** With minor surface frame damages:  
In case of water ingress, the rubber gasket will be pressed onto the frame. Scratches and other minor paint damages may not jeopardize the watertight integrity

If the receiver is showing 0%, it is to be treated as no leakage detected.

The tone also distinguishes other ultrasonic emissions from other systems in the immediate area where the testing is being carried out.

*NB: Examples of a tone only leakage could potentially be: wear to the seals thickness, paint drops, uneven painting, dirt and other foreign objects.*

### Test result

Please mark and sign test checkpoint sheet (see page 50) for each watertight door after completion of testing. If a leakage is found please mark as in Figure 8.5. Please "OK" the door in Remarks if the test was successful.

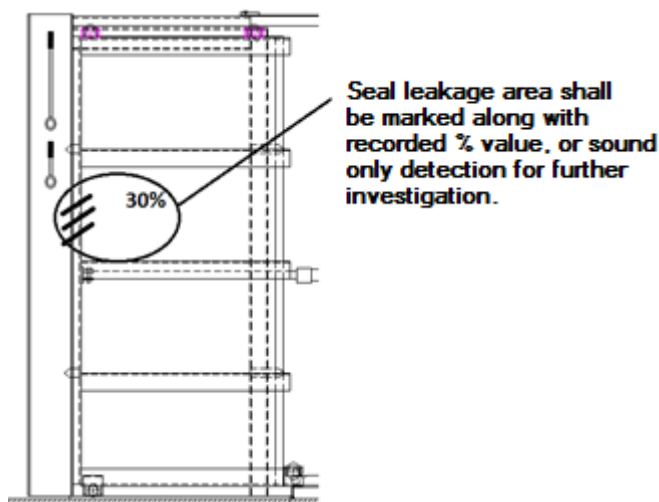

Figure 8.5 How to report on a leakage area found

*A copy of the next page (49) shall be made for each door.*



# Report Sheet for Recording Testing of a Watertight Door

Project \_\_\_\_\_

Door No: \_\_\_\_\_

Door type: \_\_\_\_\_

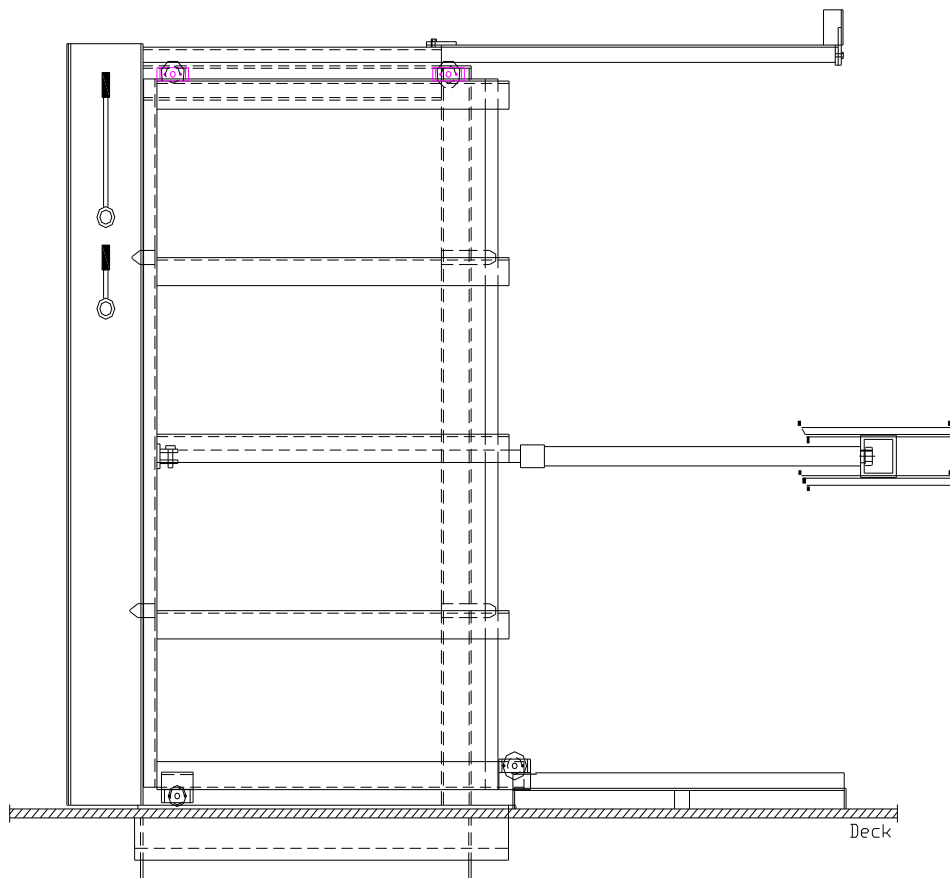

Sign service engineer /Date \_\_\_\_\_

Owner sign/Date \_\_\_\_\_

Class sign/Date \_\_\_\_\_

Remarks:  
\_\_\_\_\_  
\_\_\_\_\_

## 9. Troubleshooting

### Transmitter Power Seems Low

Use the receiver and perform an Emitter Test on all the emitters to check for any defective emitters (page 25). The transmitter can be used with up to 2 defective emitters (until it can be repaired, providing the surveyor is satisfied that sufficient sound coverage can be achieved) but any more and the transmitter must be repaired.

Has water got into any of the emitters? Water or any liquid will stop the ultrasound output if it gets into the emitters. Dry out the water, and then check each emitter is working using the Emitter Test (page 25).

Check that the Power Level on the Transmitter is set to Max.

### Unable to Set an Open Hatch Value

Too Much Ultrasound? If the receiver is giving you the message "SIGNAL TOO HIGH" when trying to set an Open Hatch value then you may be too close to the transmitter and (or) you can't get a 0% reading anywhere.

First try moving the transmitter further away, and then reduce the Power Level of the transmitter by one 'click'.

Too Little Ultrasound signal? If the receiver is giving you the message "SIGNAL TOO LOW" when trying to set an Open Hatch value there are a few possible reasons;

1. If the cargo area is very large (long) you may be simply too far away from the transmitter. The ultrasound energy may be below the minimum required to set an Open Hatch Value. In this case you should consider splitting the area into smaller sections (page 31).
2. You should also perform an Emitter Test to verify the transmitter is performing correctly (see page 25).

3. Has the inspection microphone been damaged or immersed in water/oil? Try using the other inspection microphone supplied with the kit.
4. Confirm that the transmitter is set to MAX power.

### **Intermittent Receiver Signal Level**

If you are experiencing intermittent jumps in receiver signal level while conducting a survey there are a few possible causes;

1. Stray ultrasound coming from another source. Although the Hatch Sure receiver is tuned to detect the signal from the Hatch Sure transmitter it is possible for other ultrasound signals at the same frequency to be detected. By listening with the headphones to the signals being received, identify and locate the source of the ultrasound noise and then take action to reduce or silence it.
2. There could be a fault with the extension cable or inspection microphone. Try using the emergency extension cable supplied with the kit to see if the problem lies with the extension. Try using the other inspection microphone. See page 23 Testing Inspection Microphones.

## 10. Care, Servicing & Calibration

### Cleaning

- ✓ Clean the equipment and accessories with a damp cloth
- ✗ Do not use solvents to clean the equipment
- ✗ Do not use any abrasive cleaner, especially on the display window
- ✗ Do not immerse the equipment in liquid when cleaning

### Batteries

- ✓ Always remove the batteries if the equipment will not be used for more than a few days
- ✓ Only use leak-proof batteries

### Environmental

- ✗ Do not immerse the equipment in liquids
- ✗ Do not subject the equipment to temperatures greater than 60°C (140°F)
- ✗ Do not store the equipment for long periods in conditions of high humidity

### Repairs

- ✗ There are no user serviceable parts inside. Therefore all repair work should be carried out by Cygnus Instruments or by an Authorised Cygnus Service Centre.

## Returning the Equipment for Servicing

A full Manufacturer's Factory Service is available from Cygnus Instruments.



The Complete Kit should always be returned for Service or Repair, including all Batteries and Leads.

Cygnus equipment is renowned for its reliability, sometimes problems with getting measurements are simply due to the way the equipment is being used.

However, if you do need to return items for repair please let us know the details of the problem to help us guarantee the best possible service.

## Calibration

The Hatch Sure equipment is supplied tested and calibrated from new and a calibration certificate is issued. As with all measurement equipment it is essential that its performance is checked on a regular basis to ensure it is operating within specifications.

Cygnus recommends the Hatch Sure kit is returned to Cygnus Instruments or an authorised Cygnus Agent Service Centre for a comprehensive test and calibration resulting in the issue of a new calibration certificate. This service will check the following items;

1. Transmitter output power
2. Emitter performance
3. Receiver sensitivity
4. Microphone sensitivity
5. Battery condition
6. Cable condition

## 11. Spares and Accessories

<b>Description</b>	<b>Order Code</b>
Inspection Microphone	006-1020/006-1021
Telescopic Extension	006-1003
Neckband Headphones	006-1004
MaxE AA Batteries (pack of six)	006-1005
MaxE 9v PP3 Battery (each)	006-1006
Battery Charger	006-1007
DC Power Lead for Transmitter	006-1008
Ruck Sack Soft Carry Case for Hatch Sure kit	006-1009
Hatch Sure Transmitter in Pouch	006-1010
Hatch Sure Receiver in Pouch	006-1012

## 12. Information

### Technical Specifications

<b>Hatch Sure Receiver</b>	
<b>Size</b>	110mm x 185mm x 45mm (4.4" x 7.3" x 1.8") W x H x D
<b>Weight</b>	500g (17 oz) including battery
<b>Power</b>	9v PP3 battery – 2 x MaxE rechargeable batteries supplied
<b>Battery Life</b>	4-5 hrs continuous with MaxE rechargeable battery 8-9 hrs continuous with Alkaline battery
<b>Protection</b>	IP65 (IP66 in soft pouch)
<b>Frequency</b>	40.000 KHz, Bandwidth $\pm 200$ Hz
<b>Enclosure</b>	ABS plastic with orange shock-absorbing outer boot. Outdoor all weather soft pouch with waist mounted belt strap.
<b>Temperature Range</b>	Operating -20° C to +50° C Storage -10° C to +60° C
<b>Keys</b>	Display – Hold / Maximum Reset Measurement Units - dB / OHV Power - On/Off Backlight – On/Off Set Open Hatch Reference Level Transmitter Remote Control – On/Off Headphone Volume – Increase / Decrease Emitter Test Function
<b>Display</b>	Liquid Crystal 5 cm x 3cm, 128x64 pixels, Graphic. Backlight with white LEDs.
<b>Storage Memory</b>	Non-Volatile EEPROM memory stores all modes and calibration values even when the battery is removed.
<b>Remote Control Transmitter</b>	433.92 MHz ASK, Power = 10 dBm
<b>Headphone Socket</b>	3.5mm Stereo Socket, 4 Ohm.
<b>Microphone</b>	12mm diameter receiver mounted on 200mm stainless steel gooseneck, fitted to telescopic extension extending from 50cm to 110cm in three sections. Electrical connections via BNC connectors.
<b>Emitter Test Function</b>	This test function allows each emitter to be tested and evaluated for output sound pressure level.
<b>Maximum Value Function</b>	Records and displays the maximum (peak) signal level value measured. The maximum can be reset back to zero at any time by the user.
<b>Display Hold Function</b>	Allows the user to hold (freeze) the display with the current signal level measurements.
<b>Signal Measurement Units</b>	Allows either dB or OHV (Open Hatch Value) to be displayed as the main reading, the other value is shown at the bottom of the screen also.
<b>Low Battery Warning</b>	Battery level graphic on the display shows battery voltage level. Low battery warning message flashed on the display.
<b>Set OHV function</b>	Calibrates the Open Hatch Value to 100 % using the current received signal level. The user has the option to adjust this

	calibration value before accepting it. The calibration value is stored in non-volatile memory and is retained while the power is off.
<b>Transmitter Remote Control</b>	Allows the user to turn the transmitter unit on/off remotely.
<b>Compliance</b>	CE UKCA RoHS
<b>Warranty</b>	3 years

<b>Hatch Sure Microphone</b>	
<b>Size</b>	Length 240mm (9.4 inch), Diameter 15mm (0.6 inch)
<b>Material</b>	Nickel Plated / Stainless Steel
<b>Weight</b>	75g (2.6 oz)
<b>Receiver</b>	10 mm diameter ultrasonic receiver.
<b>Frequency</b>	40 KHz, 3KHz Bandwidth.
<b>Sensitivity</b>	At 40 KHz – 70 db/V/mbar
<b>Beam Angle</b>	72° -6 dB
<b>Warranty</b>	6 months

<b>Hatch Sure Telescopic Extension</b>	
<b>Size</b>	Extended Length 1.215m (4 feet) Collapsed Length 0.4m (16 inch)
<b>Weight</b>	300g (10 oz)
<b>Warranty</b>	1 year

<b>Hatch Sure Transmitter</b>	
<b>Size</b>	120 mm x 150 mm x 90 mm (4.7" x 5.9" x 3.5") W x H x D
<b>Weight</b>	680g (24 oz) including batteries
<b>Power</b>	6 x AA batteries (12 x Rechargeable MaxE 2100 mAh supplied with kit). External 12-24 v DC power input socket (1 amp).
<b>Battery Life</b>	4 hrs with 2100 mAh MaxE batteries
<b>Battery Charger</b>	A six cell charger is supplied. 100 to 240 v AC 50-60 Hz Supply. Charge time is approx. 3 hours.
<b>Protection</b>	IP40 in soft-pouch with emitters exposed (normal use). IP42 in soft-pouch with cover flat secured (storage).
<b>Transmitter Frequency</b>	40.000 KHz, ±80 Hz Bandwidth, Frequency Modulated.
<b>Emitters</b>	19 x 16mm diameter 40 KHz ultrasound emitters.
<b>Transmitter Power</b>	130 dB (SPL) min and "Max" power level. 6 Levels of output power from Min to Max (130dB)
<b>Enclosure</b>	ABS plastic. Padded soft-pouch with protective weather cover and 4 points for attaching rope for lowering into holds.



<b>Temperature Range</b>	Operating -20° C to +50° C Storage -10° C to +60° C
<b>Switches</b>	Power – On/Off Remote Control – Off/On Both fitted with rubber boots.
<b>Low Battery Warning</b>	Unit will transmit a distinctive tone to the receiver and flash a red warning LED when the battery is getting low to alert the user. When the battery is exhausted the unit will power off automatically.
<b>Compliance</b>	CE UKCA RoHS
<b>Warranty</b>	3 years (not including batteries and charger)

*Due to Cygnus Instruments Ltd policy of continual product improvement  
Technical Specifications may be subject to change.*

### **13. Recycling and Disposal (EC Countries)**

The WEEE Directive (Waste Electrical and Electronic Equipment 2002/96.EC) has been put into place to ensure that products are recycled using best available treatment, recovery and recycling techniques to ensure human health and high environmental protection.

This equipment has been designed and manufactured with high quality materials and components which can be recycled and reused. It may contain hazardous substances that could impact health and the environment. In order to avoid the dissemination of those substances in our environment and to diminish the pressure on natural resources we encourage you to dispose of this product correctly.



DO NOT dispose of this product with general household waste.

DO dispose of the complete product including cables, plugs and accessories in the designed WEEE collection facilities.

This product may also be returned to the agent or manufacturer who supplied it for safe end-of-life disposal.

## 14. Warranty Information

### LIMITED THREE YEAR WARRANTY FOR CYGNUS ULTRASONIC EQUIPMENT

1. Cygnus Instruments Limited ("CYGNUS") warrants that, subject as set out below, the Products manufactured by it (excluding consumables, batteries, probes, leads, microphones and telescopic extensions) will be free from defects in materials and workmanship for a period of three years from the date of purchase either from CYGNUS or from an Authorised CYGNUS Distributor. Batteries, probes, leads, microphones and telescopic extensions are warranted for 6 months. This warranty is limited to the original Purchaser of the Product and is not transferable. During the warranty period, CYGNUS will repair, replace or refund, at its option, any defective Products at no additional charge, provided that the product is returned by the original Purchaser, shipping prepaid, to CYGNUS or an Authorised CYGNUS Distributor. If shipped by mail or any common carrier, the Purchaser must insure and accept all liability for loss or damage to the Product and must use shipping containers equivalent to the original packaging. Replacement products or parts will be furnished on an exchange basis only. All replaced products or parts become the property of CYGNUS.
2. Any defects in materials or workmanship must be notified to CYGNUS by the Purchaser within seven days after the discovery of the defect or failure.
3. Dated proof of purchase must be provided by the Purchaser when requesting warranty work to be performed or making any other claim under this warranty. CYGNUS will not be liable under this warranty unless the total price for the Product was paid by the due date for payment.
4. This warranty does not extend to any products which have been damaged as a result of, accident, misuse or abuse, natural or personal disaster, service, modification or repair by anyone other than CYGNUS or an Authorised CYGNUS Service Centre, failure to properly store or maintain the Product, negligence, abnormal working conditions, fair wear and tear, or failure to follow the instructions issued by CYGNUS in relation to the Product.
5. Except as expressly set forth above or in the CYGNUS Terms of Sale, subject to which the Products were purchased, all warranties, conditions or other terms implied by Statute or Common Law are extended to the fullest extent permitted by law.
6. Except in respect of death or personal injury caused by the negligence of Cygnus, Cygnus shall not be liable to the Purchaser or to any other person by reason of any representation (unless fraudulent), or any implied warranty, condition or other term, or any duty at common law, or under the express terms of the contract for purchase of the Products, for loss of profit or for any indirect, special or consequential loss or damage, costs, expenses or other claims for compensation whatsoever (whether caused by the negligence of Cygnus, its employees or agents or otherwise) which arise out of or in connection with the supply of the Products or their use or resale by the Purchaser or by any other person. The entire liability of Cygnus under or in connection with the Products shall not exceed the price paid for the Products, except as expressly provided in this warranty.

---

## Index

- Batteries
  - Charge Time, 12, 16
  - Charging, 12
- Calibration, 53
- Cleaning, 52
- Disposal, 58
- Open Hatch
  - Setting, 24
- Receiver
  - Batteries, 15
  - Battery Charging, 16
  - Headphone Socket, 15
  - Remote Control, 20
  - Remote Microphone
    - Connection, 14
  - Volume Control, 19
- Recycling, 58
- Remote Microphone
  - Testing, 23
- Service, 53
- Transmitter
  - Anchor Points, 9
  - Batteries, 12
  - Beam Pattern, 27
  - Controls, 10
  - External Power Supply, 13
  - Power Level, 31
  - Remote Control, 11
  - Testing, 25
- Warranty, 59
- WEEE Directive, 58